

THE REFERENCE

NIKEF

THE REFERENCE

THE ESSENTIAL FOR ANY AUDIOPHILE.

HAND BUILT BY THE MASTERS WHO SET THE STANDARD FOR AUDIO QUALITY, THE REFERENCE HAS BEEN THE BENCHMARK FOR LOUDSPEAKERS AND SOUND REPRODUCTION. THE REFERENCE IS AN EMBODIMENT OF KEF'S PHILOSOPHY AND THE RELENTLESS PURSUIT OF PERFECTION.

**NOW WITH KEF'S INNOVATIVE
METAMATERIAL ABSORPTION TECHNOLOGY.**

DETAIL REMASTERED

AN ICON REDEFINED FOR TOMORROW



“ A description was needed to convey the idea that every loudspeaker is subject to scrutiny at all stages of assembly, culminating in a final test comparison with a laboratory maintained reference standard. Hence the method became the name: Reference.”

Raymond Cooke OBE

KEF Founder



THE BENCHMARK OF BENCHMARKS



REFERENCE 104aB



REFERENCE 103



REFERENCE 105



REFERENCE 105.2



REFERENCE 101



REFERENCE 104/2



REFERENCE 107



REFERENCE 105/3



REFERENCE 109



REFERENCE 204C



REFERENCE 5

The Reference has continually set the benchmark for loudspeakers since its launch in 1973. The perfect reproduction of recorded sound is what The Reference has always stood for.

Pioneering the use of digital technologies to achieve the highest audio accuracy, every pair of The Reference series can be matched within half a decibel to the laboratory-maintained reference standard. Exact pair matching delivers perfect stereo reproduction, so these revolutionary speakers won acclaim for the superior acoustic precision.

Since the first generation, The Reference has been continuously enhanced by new innovations and technological developments. Groundbreaking in its first incarnation, each subsequent iteration of The Reference has added to the world's knowledge of the science of acoustics.

In the latest evolution, The Reference incorporates our latest innovation: Metamaterial Absorption Technology (MAT) and continues to be the supreme expression of KEF's philosophy, where advanced engineering meets inspired design.

REVOLUTIONARY SOUND ABSORPTION WITH MAT™

A truly revolutionary tool in the KEF acoustic armoury, MAT™ breaks completely new ground in speaker design.

Metamaterial Absorption Technology (MAT) is a highly complex maze-like structure, where each of the intricate channels efficiently absorbs a specific frequency. When combined, the channels act as an acoustic black hole, absorbing 99% of the unwanted sound that comes from the rear of the tweeter, eliminating the resulting distortion and providing a purer, more natural acoustic performance.

Metamaterials are specially developed structures that use existing materials in such a way that they exhibit new, desirable properties that are simply not found in naturally occurring substances.

A result of joint development with the Acoustic Metamaterials Group, using MAT breaks completely new ground in loudspeaker design, and once again demonstrates KEF's unrelenting passion for developing new technologies to improve your listening experience.



"A clever way of absorbing unwanted sound waves."

- What Hi-Fi? Innovation of the Year 2020



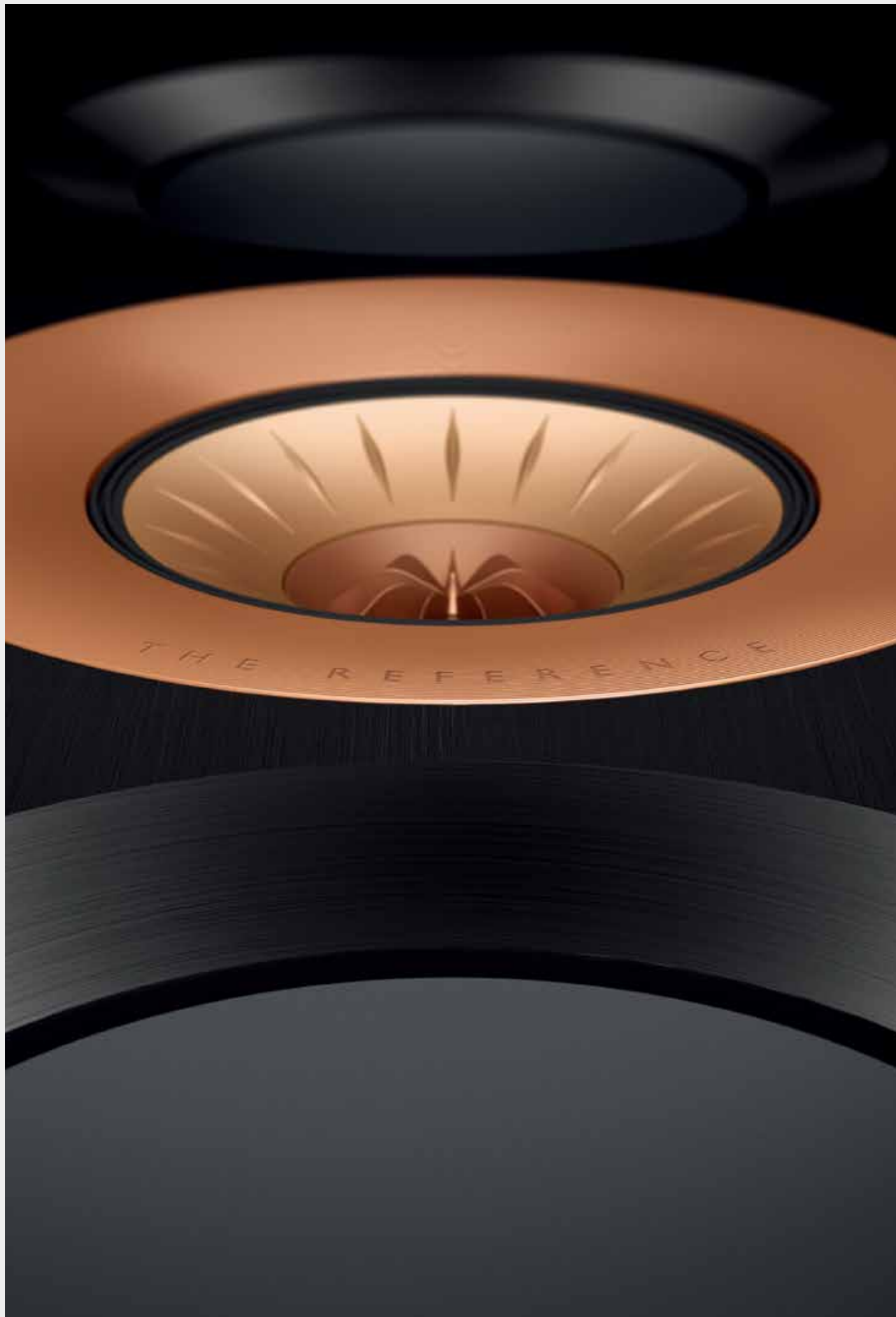

A CLASS APART



Every speaker in The Reference range exudes the sense of sheer quality that comes from being hand-built by KEF's master craftsman in Maidstone, Kent, UK. The Reference speakers are designed to be acoustically exceptional, attractive to look at, and each speaker is meticulously built to KEF's exceptional standards.

The Reference range encompasses two three-way floorstanding speakers, a formidable three-way standmount speaker, and two three-way centre speakers that can be used as Left-Centre-Right (LCR) speakers, and a 1000-watt subwoofer.

The Reference combines phenomenal high-fidelity performance with complete multi-channel versatility. And now new technological advances make The Reference range even more impressive. At the heart of The Reference range now sits a bespoke 12th generation Uni-Q with MAT driver array. This new addition truly puts The Reference range in a class of its own.

SIT ANYWHERE, HEAR EVERY DETAIL

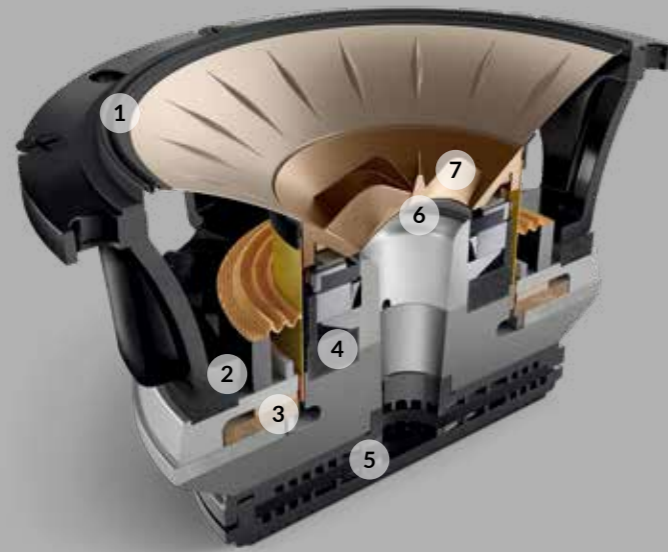

Uni-Q technology places the tweeter precisely at the acoustic centre of the bass/midrange cone, so both act together as a single point source to disperse sound more evenly throughout the room. The result is the elimination of the limited 'sweet spot', therefore allowing everybody sitting at different spots in the room to experience and enjoy the same natural, detailed sound.

Refined through iterations, the latest Uni-Q driver array for The Reference is the 12th generation Uni-Q with MAT™. A bespoke driver array engineered to deliver pristine performance, it is the result of decades of accumulated in-house knowledge and the application of cutting-edge simulation and analysis tools.

1 Driver surround

A new driver surround is designed to allow longer excursion without causing diffraction and extending the frequency range of the mid-frequency. Plus, the contours of the dome, midrange horn and surround are all computer-optimised to ensure a perfectly smooth transition to the cabinet.

2 Flexible decoupling chassis

A new flexible decoupling chassis is designed to reduce vibration and reduce coloration. It ensures that any vibrations generated by the mid and high-frequency motor system are not transmitted to the loudspeaker cabinet.

3 Ultra-low distortion MF motor

A new ultra-low distortion

midrange motor design uses a copper ring embedded into the motor gap to minimise inductance and variation of inductance with coil position. This lowers the midrange THD and reduces thermal compression, leading to improved efficiency.

4 Tweeter gap damper

The tweeter gap damper is re-engineered to maximise the space at the back of the tweeter for the new metamaterial absorber.

5 MAT tweeter absorber

The MAT tweeter absorber is a highly complex maze-like structure, where each of the intricate channels efficiently absorbs a specific frequency.

REFERENCE QUALITY BASS

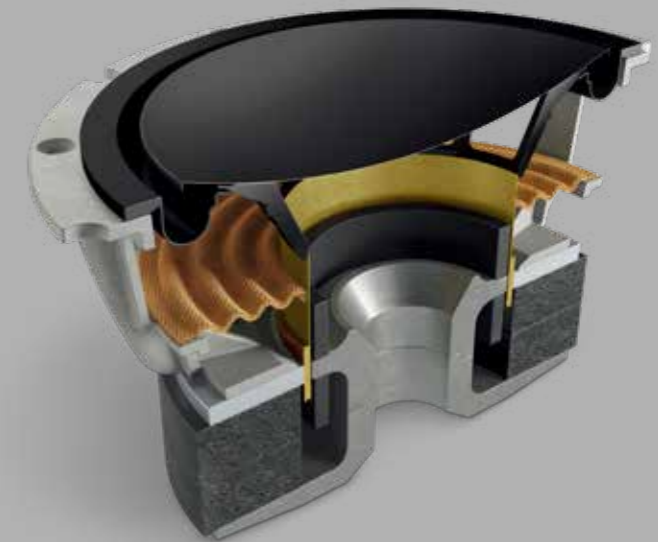

When combined, the channels absorb 99% of the unwanted sound from the rear of the tweeter.

6 Tweeter dome

The new stiffened aluminium tweeter dome that sits at the centre of the state-of-the-art Uni-Q driver array is capable of delivering consistently sweet, lucid and lyrical treble, irrespective of the volume.

7 Tangerine waveguide

The patented tangerine waveguide technology manages the airflow to recreate the wide, even spread of a natural sound field, dispersing the astonishingly pure high-frequency imaging throughout the room.

Clean, rich and precisely articulated bass adds enormously to the enjoyment of stereo or multi-channel sound.

The Reference's 165mm (6.5 inch) low frequency driver perfectly complements the new 12th generation Uni-Q driver array. With a massive vented magnet assembly and a large aluminium wire voice coil driving an exceptionally light, stiff and strong aluminium diaphragm rather than a conventional cone, the dynamics and power handling are outstanding. The distortion performance is also superb. Played loud or soft, in delicate passages or for full-on bass effects, the combination of advanced materials, smart engineering and meticulous attention to detail enables the bass to blend seamlessly with the immaculate midrange and treble.

THE SMALLEST DETAILS, REVEALED

The Reference drivers are set in a smooth, strikingly distinctive front baffle. Made from an exceptionally strong laminated aluminium and resin composite, formed in a press under extreme temperatures, it adds tremendous rigidity to the cabinet structure. The baffle also has an acoustic damping function, being connected resiliently to the cabinet via high-loss pads and secured by high tensile bolts. Shadow Flare drastically reduces harmful cabinet diffraction, allowing Uni-Q to work at its highest level. A precision-designed surface extends the waveguide effect of Uni-Q for improved clarity, particularly when it comes to the subtle nuances of plucked strings and other percussive sounds.



ENGINEERED TO BE FLEXIBLE

The Reference speakers are welcomingly undemanding in terms of positioning and are easy to fine-tune for your listening area by using KEF's innovative Flexible Port Technology, which can reduce port resonance.

There are two options of port tubes, allowing users to modify the sound to suit their room. Plus, the flare and profile of each port has been calculated by computational fluid dynamics to avoid turbulent air noise that might colour the sound, another part of the complex jigsaw that is The Reference's breath-taking performance.





COMPUTER-MODELLED CABINET

Finished by hand in pair-matched wood veneers or sumptuous high-gloss to complement the sleek composite front baffle, the beauty of The Reference cabinets lies deeper than their purposeful architectural looks.

Expertly engineered using finite element analysis to determine the ideal shape and bracing geometry, the structure is carefully designed to minimise the effect of standing waves, which can otherwise cause irregularity and resonance in driver output. By using constrained layer damping techniques to absorb unwanted vibrations and massive internal bracing to strengthen the entire structure, The Reference enclosures are virtually inert. And with no panel resonance, stray reflections or box coloration effects to muddy the sound, the midrange and bass you hear is exceptionally smooth, clean and pure.







REFERENCE 5 Meta



If you are serious about experiencing the ultimate in sound reproduction, the Reference 5 Meta exemplifies the passion for innovation that underpins The Reference design philosophy.

Each of the three-way floorstanding loudspeakers aligns four powerful 165mm (6.5 inch) bass drivers and the 12th generation Uni-Q point source driver array, with 125mm (5 inch) midrange cone and 25mm (1 inch) aluminium dome tweeter with MAT™.

With KEF's patented tangerine waveguide acting like an acoustic lens to optimise the wave front, the dispersion is wider and more even than is possible with any conventional speaker – and with

no surface discontinuities to muddy the sound, the clarity is exceptional. The bass extension of four potent LF drivers with a combined radiating area equal to a 12-inch subwoofer is as lavish as you would expect, but with far lower distortion. Low frequencies are reproduced with agility and total control, seamlessly integrating with the Uni-Q output to create an all-enveloping soundfield of accuracy and depth. The new addition of MAT absorbs 99% of the unwanted sound that comes from the rear of the tweeter, eliminating the resulting distortion and providing a more natural acoustic performance. For music or film, it is quite literally a revelation.

REFERENCE 3 Meta



Sharing the design DNA of Reference 5 Meta, Reference 3 Meta has the same uncanny ability to generate an intricate, emotionally compelling three-dimensional soundstage that places you right at the heart of the original performance.

At its heart sits the 12th generation Uni-Q driver array with Metamaterial Absorption Technology (MAT), the latest technological development from KEF, and one which puts you solidly at the heart of the action. The Three-way design with two 165mm (6.5 inch) bass drivers perfectly positioned above and below the Uni-Q point source driver array. Fidelity across the midrange and treble is outstanding, with

a smooth, flat on-axis frequency response and balanced response in other directions.

Together with Uni-Q's broad, inclusive dispersion characteristics, the Reference 3 Meta allows everyone in the room to enjoy the same rich, spatially precise acoustics without being restricted to a conventional 'sweet spot'. Lyrical, finely nuanced and astonishingly powerful when required, the speakers intensify the experience of music or drama like few other speakers can.





REFERENCE 1 Meta



The one standmount model in the Reference series, Reference 1 Meta could be the only loudspeaker you need to enjoy expansive, premium quality sound. A three-way design of high-performance capabilities, it incorporates all the groundbreaking innovations of the 12th generation Uni-Q driver array with Metamaterial Absorption Technology (MAT).

Pairing the Uni-Q MF/HF driver array with the 165mm (6.5 inch) aluminium cone bass driver, Reference 1 Meta creates a compellingly realistic soundstage out of all proportion to its relatively modest size.

Mounted on shelves or the KEF S-RF1 floor stands, the

inherently wide, even dispersion characteristics that distinguish the Uni-Q driver array also makes Reference 1 Meta an ideal rear channel home theatre speaker in a system with the power to touch your heart as well as your mind.



REFERENCE 4 Meta



As the main source of dialogue and vocals, the centre channel is critical to the realism of the home theatre experience and your emotional engagement with what is on screen.

By placing the latest 12th generation Uni-Q point source driver array with MAT between four 165mm (6.5 inch) bass drivers, Reference 4 Meta reproduces every last detail of what the director or the artist intended with total fidelity – spatially precise, stunningly clear and with a dynamic range that

takes rapid transitions effortlessly in its stride. This centre speaker can also be used as Left-Centre-Right speaker for home theatre setup.

For movie lovers looking for total immersion, Reference 4 Meta is the last word in absolute quality. For clarity, detail and emotional depth, it is a revelation.



REFERENCE 2 Meta



With the same 12th generation Uni-Q point source driver array with MAT flanked by two powerful 165mm (6.5 inch) bass drivers in a close-box design, Reference 2 Meta has the uncanny ability to completely immerse you in both music and movies.

Designed for people with smaller rooms but demand full-scale, high-performance sound, Reference 2 Meta delivers on both fronts.

It reveals all the subtleties embedded in movie soundtracks and music recordings with the same astonishing realism and clarity as the larger Reference 4 Meta. The dynamics, spatial precision and dispersion characteristics are just as outstanding, with the innovative configuration of advanced drivers flawlessly integrating LF, MF and HF response to reproduce every detail of the recorded signal with total fidelity.



PERFORMANCE PLINTHS AND STANDS



To prevent any vestigial cabinet vibrations from being transmitted through the floor of the listening area, Reference 5 Meta and Reference 3 Meta are solidly grounded on a performance plinth and spike set developed with attention to detail. The precision-engineered plinth has a built-in spirit level, and the spike sets are cleverly designed for ease of adjustment, with the screws neatly concealed by a smart machined cap.

The S-RF1 Floor Stand provides the perfect platform for your speakers to perform. Designed to partner Reference 1 Meta speakers, they boast a mounting system with integrated cable management that allows wires to be hidden.



SPECIFICATIONS



| Model | REFERENCE 1 Meta | REFERENCE 3 Meta | REFERENCE 5 Meta |
|---|--|--|--|
| Design | Three-way bass reflex | Three-way bass reflex | Three-way bass reflex |
| Drive units | Uni-Q driver array: HF: 25 mm (1 in.) aluminium dome with MAT MF: 125 mm (5 in.) aluminium cone Bass units: LF: 165 mm (6.5 in.) aluminium cone | Uni-Q driver array: HF: 25 mm (1 in.) aluminium dome with MAT MF: 125 mm (5 in.) aluminium cone Bass units: LF: 2 x 165 mm (6.5 in.) aluminium cone | Uni-Q driver array: HF: 25 mm (1 in.) aluminium dome with MAT MF: 125 mm (5 in.) aluminium cone Bass units: LF: 4 x 165 mm (6.5 in.) aluminium cone |
| Frequency range free field (-6dB) | Short port: 40 Hz - 45 kHz Long port: 37 Hz - 45 kHz | Short port: 38 Hz - 45 kHz Long port: 35 Hz - 45 kHz | Short port: 35 Hz - 45 kHz Long port: 32 Hz - 45 kHz |
| Frequency range typical in room bass response (-6dB) | 30 Hz | 28 Hz | 25 Hz |
| Frequency response (±3dB) | 45 Hz - 35 kHz | 43 Hz - 35 kHz | 40 Hz - 35 kHz |
| Crossover frequency | 450 Hz, 2.1 kHz | 450 Hz, 2.1 kHz | 450 Hz, 2.1 kHz |
| Amplifier requirements | 50 - 200 W | 50 - 300 W | 50 - 400 W |
| Sensitivity (2.83V/ 1m) | 85 dB | 86 dB | 88 dB |
| Harmonic distortion 2 nd & 3 rd harmonics (90dB, 1m) | <0.5% 40 Hz - 100 kHz <0.2% 200 Hz - 2 kHz <0.1% 2 kHz - 20 kHz | <0.5% 40 Hz - 100 kHz <0.2% 200 Hz - 2 kHz <0.1% 2 kHz - 20 kHz | <0.5% 40 Hz - 100 kHz <0.2% 200 Hz - 2 kHz <0.1% 2 kHz - 20 kHz |
| Maximum output (peak sound pressure level at 1m with pink noise) | 111 dB | 113.5 dB | 116 dB |
| Impedance | 4 Ω (min. 3.2 Ω) | 4 Ω (min. 3.2 Ω) | 4 Ω (min. 3.2 Ω) |
| Weight | 18.2 kg (40.1 lbs.) | 51.3 kg (113.1 lbs.) | 60.2 kg (132.7 lbs.) |
| Dimensions (H x W x D) (with grille and terminal) | 440 x 205 x 422 mm (17.3 x 8.1 x 16.6 in.) | 1155 x 205 x 462 mm (45.5 x 8.1 x 18.2 in.) | 1350 x 205 x 462 mm (53.1 x 8.1 x 18.2 in.) |
| Dimensions (H x W x D) (with grille, terminal & plinth) | N/A | 1207 x 323 x 467 mm (47.5 x 12.7 x 18.4 in.) | 1402 x 323 x 467 mm (55.2 x 12.7 x 18.4 in.) |
| Standard finishes | High-Gloss White/Blue, High-Gloss White/Champagne, High-Gloss Black/Grey, High-Gloss Black/Copper, Satin Walnut/Silver | | |

| Model | REFERENCE 2 Meta | REFERENCE 4 Meta |
|---|--|--|
| Design | Three-way closed box | Three-way bass reflex |
| Drive units | Uni-Q driver array: HF: 25 mm (1 in.) aluminium dome with MAT MF: 125 mm (5 in.) aluminium cone Bass units: LF: 2 x 165 mm (6.5 in.) aluminium cone | Uni-Q driver array: HF: 25 mm (1 in.) aluminium dome with MAT MF: 125 mm (5 in.) aluminium cone Bass units: LF: 4 x 165 mm (6.5 in.) aluminium cone |
| Frequency range free field (-6dB) | 65 Hz - 45 kHz | Short port: 43 Hz - 45 kHz Long port: 40 Hz - 45 kHz |
| Frequency range typical in room bass response (-6dB) | 46 Hz | 33 Hz |
| Frequency response (±3dB) | 80 Hz - 35 kHz | 48 Hz - 35 kHz |
| Crossover frequency | 450 Hz, 2.1 kHz | 450 Hz, 2.1 kHz |
| Amplifier requirements | 50 - 300 W | 50 - 400 W |
| Sensitivity (2.83V/ 1m) | 86 dB | 88 dB |
| Harmonic distortion 2 nd & 3 rd harmonics (90dB, 1m) | <0.5% 40 Hz - 100 kHz <0.2% 200 Hz - 2 kHz <0.1% 2 kHz - 20 kHz | <0.5% 40 Hz - 100 kHz <0.2% 200 Hz - 2 kHz <0.1% 2 kHz - 20 kHz |
| Maximum output (peak sound pressure level at 1m with pink noise) | 113.5 dB | 116 dB |
| Impedance | 4 Ω (min. 3.2 Ω) | 4 Ω (min. 3.2 Ω) |
| Weight | 22.8 kg (50.3 lbs.) | 45.2 kg (99.6 lbs.) |
| Dimensions (H x W x D) (with grille and terminal) | 205 x 630 x 335 mm (8.1 x 24.8 x 13.2 in.) | 205 x 1090 x 463 mm (8.1 x 42.9 x 18.2 in.) |
| Dimensions (H x W x D) (with grille, terminal & plinth) | N/A | N/A |
| Standard finishes | High-Gloss White/Blue, High-Gloss White/Champagne, High-Gloss Black/ Grey, High-Gloss Black/Copper, Satin Walnut/Silver | |

| Model | REFERENCE 8b |
|---|--|
| Design | Force cancelled closed box |
| LF Drive unit | 2 x 225mm (9 in.) |
| Frequency range at 90dB output in free-space mode (-6dB) | 18Hz |
| Frequency response at 90dB output in free-space mode (±3dB) | 24Hz |
| Amplifier | 2 x 500W Class D with switched mode power supply and DSP based control section |
| Maximum output (peak sound pressure level at 1m 50Hz) | 110dB |
| Low pass filter variable | Variable frequency: 40Hz to 160Hz Variable slope: 12dB/oct, 18dB/oct, 24dB/oct LFE mode: 350Hz, 18dB/oct |
| Inputs | RCA phono sockets Analogue XLR socket Speaker level inputs |
| Link out | RCA phono sockets |
| Net internal volume | 23L |
| Weight | 34kg (75.0lbs.) |
| Dimensions (H x W x D) | 398 x 365 x 429 mm (15.7 x 14.4 x 16.8 in.) |
| Power requirements | 100V - 120V / 220V - 240V ~50/60Hz |
| Power consumption | 1000W |
| Cabinet finish | Deep Piano Black |
| Kent Engineering and Foundry Edition | N/A |

KEF reserves the right, in line with continuing research and development, to amend or change specifications. E&OE

FINISHES



The expertly engineered cabinets are finished in a sumptuous high-gloss or richly detailed, pair-matched wood veneers to complement the strikingly distinctive front baffle. Five finishes are available, a combination of three cabinet finishes and five drive unit colours: High-Gloss Black/Copper, High-Gloss Black/Grey, High-Gloss White/Blue, High-Gloss White/Champagne, and Satin Walnut/Silver .



High-Gloss Black/Copper



High-Gloss Black/Grey



High-Gloss White/Blue



High-Gloss White/Champagne



Satin Walnut/Silver

REFERENCE 8b



To experience the full impact of dramatic on-screen effects in a home theatre system, bass precision and control are as important as its extension. You want powerful and articulate, not vague or smudged. That's why the Reference 8b subwoofer boasts two 500W Class D amplifiers, each driving a 228mm (9 inch) long-throw, ultra-low distortion driver.

Using KEF's ingenious force-cancelling technology, these

formidably powerful drive units are connected back-to-back in the heavily braced, acoustically inert cabinet. By cancelling out the forces they generate, this configuration allows both driver units to operate more effectively, giving noticeably greater definition to low frequency effects. If you have not experienced a truly great subwoofer, you will be amazed what a difference it makes to your viewing and listening pleasure.



EXPERIENCE THE REFERENCE

The proof is in the listening.
Hearing The Reference in all its
glory is the only way to appreciate
exactly what this loudspeaker is
capable of.

Find a retailer



